

# ASME B16.5 Flanges

**Types:** ASME B16.5 Weld Neck Flanges, ASME B16.5 Slip-On Flanges, ASME B16.5 Socket Weld Flanges, ASME B16.5 Threaded Flanges, ASME B16.5 Lap Joint Flanges, ASME B16.5 Blind Flanges.

1/2" - 24" Class 150, 300, 400, 600, 900, 1500 and 2500

**NOTE:** Reducing flanges are available in all types and pressures.

To order a reducing flange, state the smaller size first, then the outside diameter of the larger size.

**Example:** 1" X 7½" O.D. 150 SO RF reducing would be a 3" X 1" Slip-on, Raised Faced Reducing. Or, to simplify, just state the actual pipe sizes in order of larger to smaller.

**Example:** 3" X 1" Slip-on Flanges, ASME B16.5 Raised Faced Flanges, ASME B16.5 Reducing Flanges.

ASME B16.5

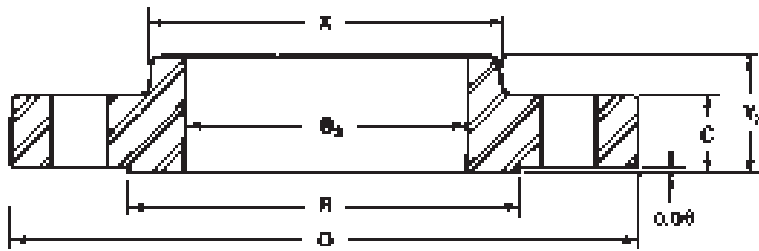

SLIP-ON

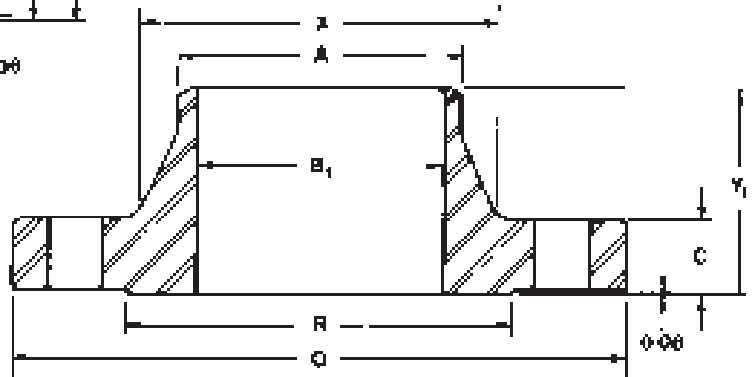

WELDING NECK

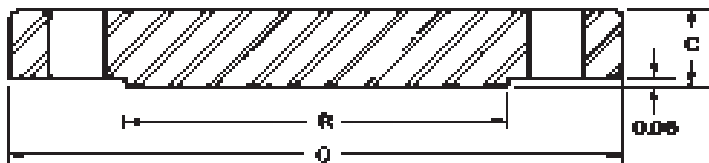

BLIND

Nominal Size	Common Dimensions				Bore			Length Thru Hub		
	Outside Dia. O	Thk. C	Raised Face Dia. R	Fillet Radius r	Welding Neck Socket B <sub>1</sub>	Slip-on B <sub>2</sub>	Lap Joint B <sub>3</sub>	Welding Neck Y <sub>1</sub>	Slip-on Socket Y <sub>2</sub>	Lap Joint Y <sub>3</sub>
1/2	3.50	0.44	1.38	0.12	To be specified by purchaser.	0.88	0.90	1.88	0.62	0.62
3/4	3.88	0.50	1.69	0.12		1.09	1.11	2.06	0.62	0.62
1	4.25	0.56	2.00	0.12		1.36	1.38	2.19	0.69	0.69
1 1/4	4.62	0.62	2.50	0.19		1.70	1.72	2.25	0.81	0.81
1 1/2	5.00	0.69	2.88	0.25		1.95	1.97	2.44	0.88	0.88
2	6.00	0.75	3.62	0.31		2.44	2.46	2.50	1.00	1.00
2 1/2	7.00	0.88	4.12	0.31		2.94	2.97	2.75	1.12	1.12
3	7.50	0.94	5.00	0.38		3.57	3.60	2.75	1.19	1.19
3 1/2	8.50	0.94	5.50	0.38		4.07	4.10	2.81	1.25	1.25
4	9.00	0.94	6.19	0.44		4.60	4.60	3.00	1.31	1.31
5	10.00	0.94	7.31	0.44		5.66	5.69	3.50	1.44	1.44
6	11.00	1.00	8.50	0.50		6.72	6.75	3.50	1.56	1.56
8	13.50	1.12	10.62	0.50	8.72	8.75	4.00	1.75	1.75	
10	16.00	1.19	12.75	0.50	10.88	10.92	4.00	1.94	1.94	
12	19.00	1.25	15.00	0.50	12.88	12.92	4.50	2.19	2.19	
14	21.00	1.38	16.25	0.50	14.14	14.18	5.00	2.25	3.12	
16	23.50	1.44	18.50	0.50	16.16	16.19	5.00	2.50	3.44	
18	25.00	1.56	21.00	0.50	18.18	18.20	5.50	2.69	3.81	
20	27.50	1.69	23.00	0.50	20.20	20.25	5.69	2.88	4.06	
24	32.00	1.88	27.25	0.50	24.25	24.25	6.00	3.25	4.38	

ASME B16.5

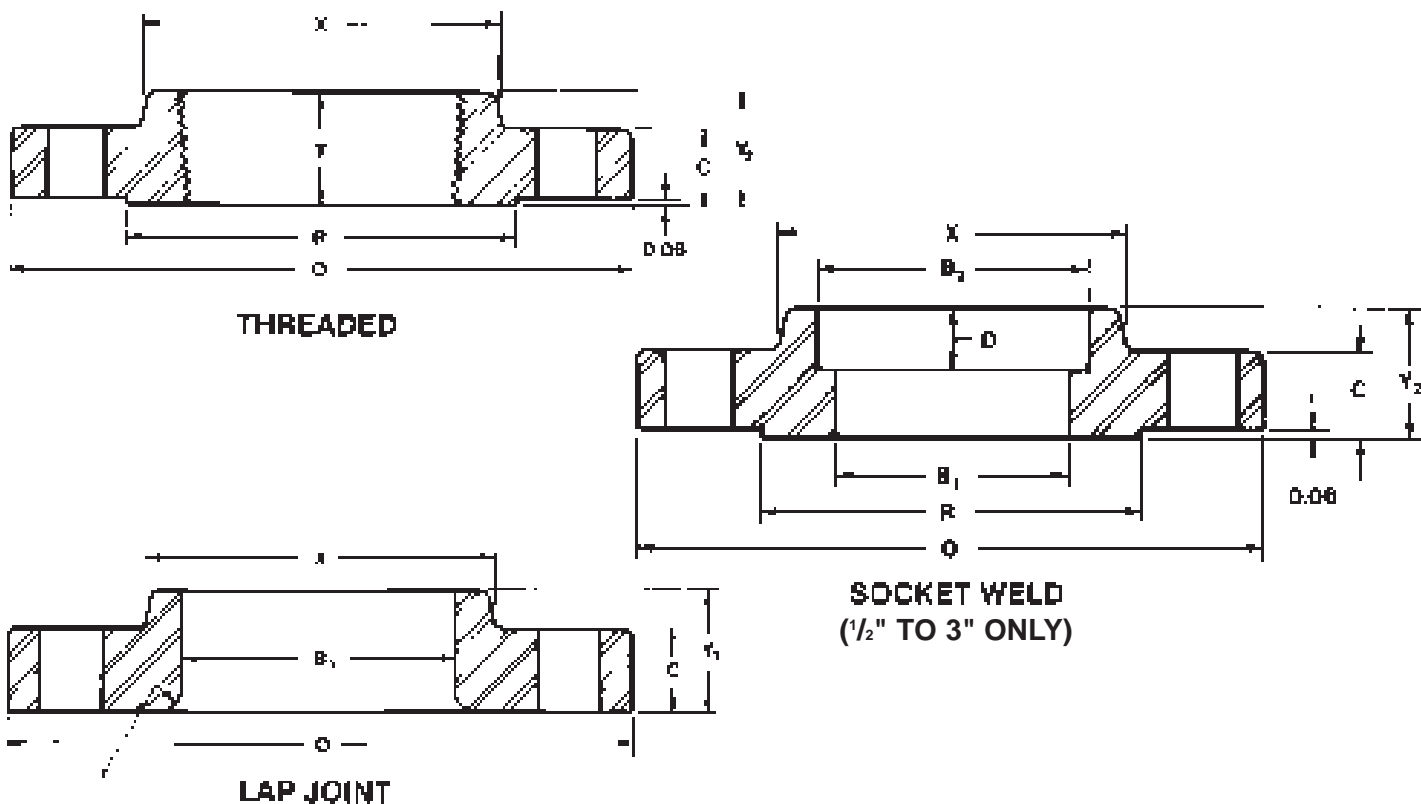

Min. Thread Length T	Depth of Socket D	Dia. Hub at Bevel A	Hub Dia. X	Drilling			Approx. Weight				Nominal Size
				Bolt Circle	Dia. Holes	No. Holes	Welding Neck	Slip-on Thrd. Sock. W.	Lap Joint	Blind	
0.62	0.38	0.84	1.19	2.38	0.62	4	2	1	1	1	1/2
0.62	0.44	1.05	1.50	2.75	0.62	4	2	2	2	2	3/4
0.69	0.50	1.32	1.94	3.12	0.62	4	3	2	2	2	1
0.81	0.56	1.66	2.31	3.50	0.62	4	3	3	3	3	1 1/4
0.88	0.62	1.90	2.56	3.88	0.62	4	4	3	3	4	1 1/2
1.00	0.69	2.38	3.06	4.75	0.75	4	6	5	5	5	2
1.12	0.75	2.88	3.56	5.50	0.75	4	8	7	7	7	2 1/2
1.19	0.81	3.50	4.25	6.00	0.75	4	10	8	8	9	3
1.25	0.88	4.00	4.81	7.00	0.75	8	12	11	11	13	3 1/2
1.31	0.94	4.50	5.31	7.50	0.75	8	15	13	13	17	4
1.44	0.94	5.56	6.44	8.50	0.88	8	19	15	15	20	5
1.56	1.06	6.63	7.56	9.50	0.88	8	24	19	19	26	6
1.75	1.25	8.63	9.69	11.75	0.88	8	39	30	30	45	8
1.94	1.31	10.75	12.00	14.25	1.00	12	52	43	43	70	10
2.19	1.56	12.75	14.38	17.00	1.00	12	80	64	64	110	12
2.25	1.63	14.00	15.75	18.75	1.12	12	110	90	105	140	14
2.50	1.75	16.00	18.00	21.25	1.12	16	140	98	140	180	16
2.69	1.94	18.00	19.88	22.75	1.25	16	150	130	160	220	18
2.88	2.13	20.00	22.00	25.00	1.25	20	180	165	195	285	20
3.25	2.50	24.00	26.12	29.50	1.38	20	260	220	275	430	24

ASME B16.5

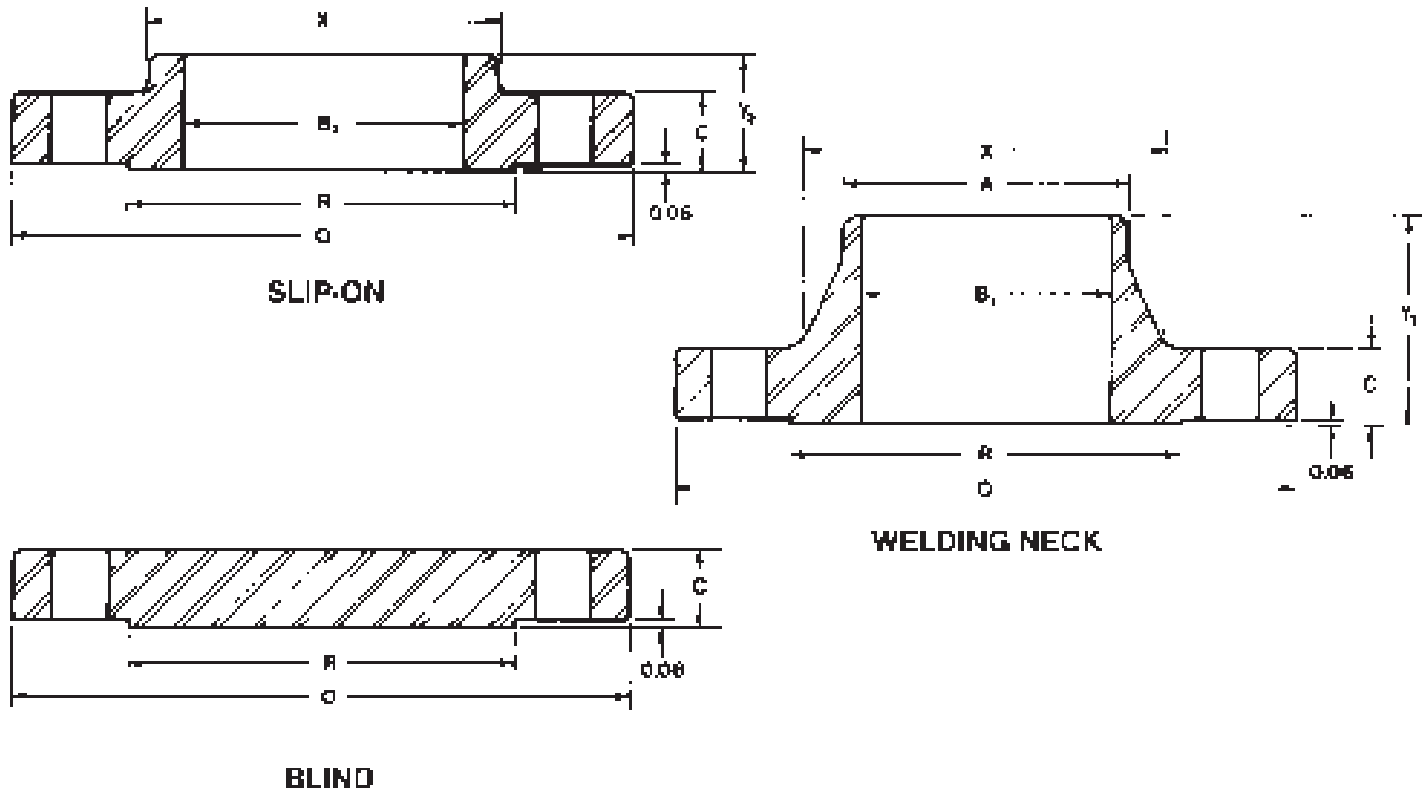

Nominal Size	Common Dimensions				Bore			Length Thru Hub		
	Outside Dia. O	Thk. C	Raised Face Dia. R	Fillet Radius r	Welding Neck Socket B <sub>1</sub>	Slip-on B <sub>2</sub>	Lap Joint B <sub>3</sub>	Welding Neck Y <sub>1</sub>	Slip-on Socket Y <sub>2</sub>	Lap Joint Y <sub>3</sub>
1/2	3.75	0.56	1.38	0.12	To be specified by purchaser.	0.88	0.90	2.06	0.88	0.88
3/4	4.62	0.62	1.69	0.12		1.09	1.11	2.25	1.00	1.00
1	4.88	0.69	2.00	0.12		1.36	1.38	2.44	1.06	1.06
1 1/4	5.25	0.75	2.50	0.19		1.70	1.72	2.56	1.06	1.06
1 1/2	6.12	0.81	2.88	0.25		1.95	1.97	2.69	1.19	1.19
2	6.50	0.88	3.62	0.31		2.44	2.46	2.75	1.31	1.31
2 1/2	7.50	1.00	4.12	0.31		2.94	2.97	3.00	1.50	1.50
3	8.25	1.12	5.00	0.38		3.57	3.60	3.12	1.69	1.69
3 1/2	9.00	1.19	5.50	0.38		4.07	4.10	3.19	1.75	1.75
4	10.00	1.25	6.19	0.44		4.57	4.60	3.38	1.88	1.88
5	11.00	1.38	7.31	0.44		5.66	5.69	3.88	2.00	2.00
6	12.50	1.44	8.50	0.50		6.72	6.75	3.88	2.06	2.06
8	15.00	1.62	10.62	0.50	8.72	8.75	4.38	2.44	2.44	
10	17.50	1.88	12.75	0.50	10.88	10.92	4.62	2.62	3.75	
12	20.50	2.00	15.00	0.50	12.88	12.92	5.12	2.88	4.00	
14	23.00	2.12	16.25	0.50	14.14	14.18	5.62	3.00	4.38	
16	25.50	2.25	18.50	0.50	16.16	16.19	5.75	3.25	4.75	
18	28.00	2.38	21.00	0.50	18.18	18.20	6.25	3.50	5.12	
20	30.50	2.50	23.00	0.50	20.20	20.25	6.38	3.75	5.50	
24	36.00	2.75	27.25	0.50	24.25	24.25	6.62	4.19	6.00	

ASME B16.5

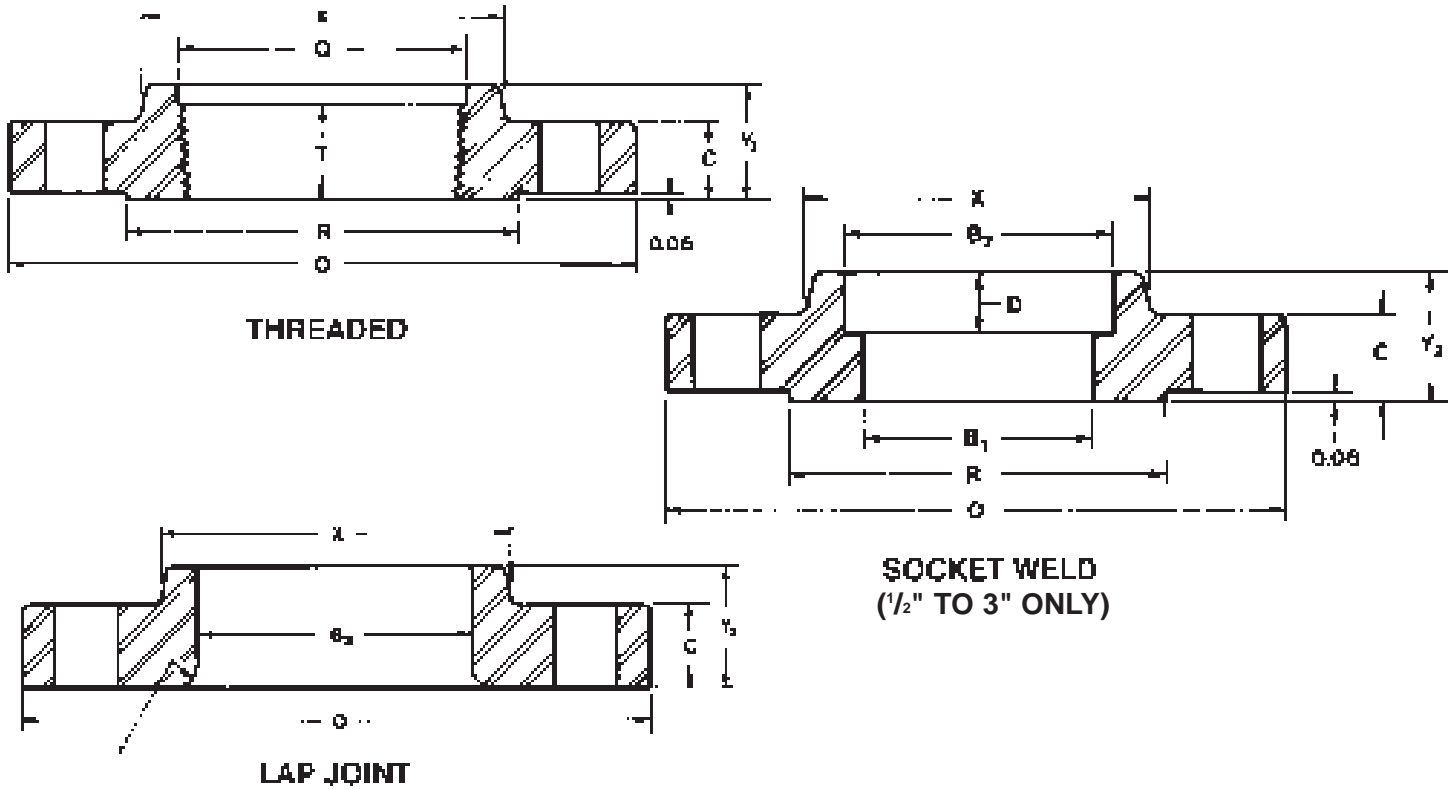

Min. Thread Length T	Dia. Counter Bore Thd. Q	Depth of Socket D	Dia. Hub at Bevel A	Hub Dia. X	Drilling			Approx. Weight				Nominal Size
					Bolt Circle	Dia. Holes	No. Holes	Welding Neck	Slip-on Thrd. Sock. W.	Lap Joint	Blind	
0.62	0.93	0.38	0.84	1.50	2.62	0.62	4	2	2	2	2	1/2
0.62	1.14	0.44	1.05	1.88	3.25	0.75	4	3	3	3	3	3/4
0.69	1.41	0.50	1.32	2.12	3.50	0.75	4	4	3	3	3	1
0.81	1.75	0.56	1.66	2.50	3.88	0.75	4	5	4	4	4	1 1/4
0.88	1.98	0.62	1.90	2.75	4.50	0.88	4	7	6	6	6	1 1/2
1.12	2.50	0.69	2.38	3.31	5.00	0.75	8	9	7	7	8	2
1.25	3.00	0.75	2.88	3.94	5.88	0.88	8	12	10	10	12	2 1/2
1.25	3.63	0.81	3.50	4.62	6.62	0.88	8	15	13	13	16	3
1.44	4.13	0.88	4.00	5.25	7.25	0.88	8	18	17	17	21	3 1/2
1.44	4.63	0.94	4.50	5.75	7.88	0.88	8	25	22	22	27	4
1.69	5.69	0.94	5.56	7.00	9.25	0.88	8	32	28	28	35	5
1.81	6.75	1.06	6.62	8.12	10.62	0.88	12	42	39	39	50	6
2.00	8.75	1.25	8.62	10.25	13.00	1.00	12	67	58	58	81	8
2.19	10.88	1.31	10.75	12.62	15.25	1.12	16	91	81	91	124	10
2.38	12.94	1.56	12.75	14.75	17.75	1.25	16	140	115	140	185	12
2.50	14.19	1.62	14.00	16.75	20.25	1.25	20	180	165	190	250	14
2.69	16.19	1.75	16.00	19.00	22.50	1.38	20	250	190	250	295	16
2.75	18.19	1.94	18.00	21.00	24.75	1.38	24	320	250	295	395	18
2.88	20.19	2.12	20.00	23.12	27.00	1.38	24	400	315	370	505	20
3.25	24.19	2.50	24.00	27.62	32.00	1.62	24	580	475	550	790	24

# Class 400

## ASME B16.5

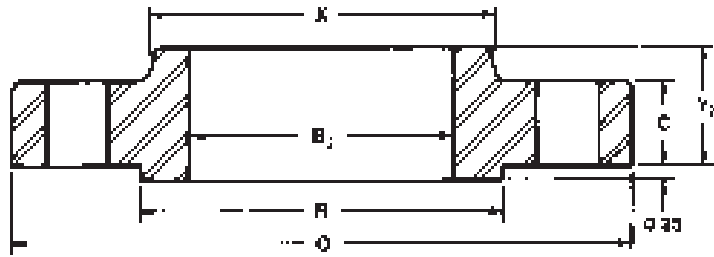

**SLIP-ON**

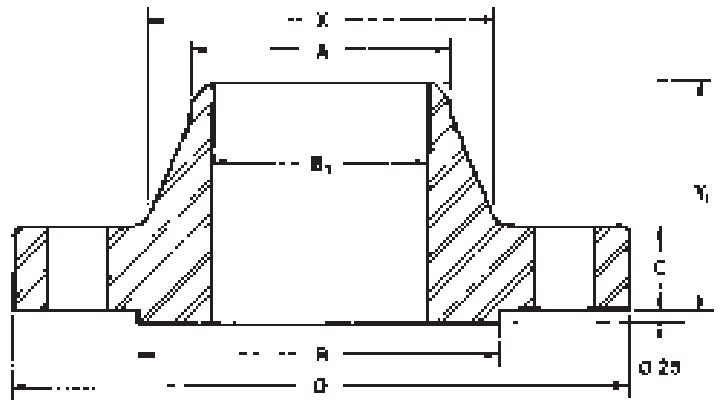

**WELDING NECK**



**BLIND**

Nominal Size	Common Dimensions				Bore			Length Thru Hub		
	Outside Dia. O	Thk. C	Raised Face Dia. R	Fillet Radius r	Welding Neck Socket B <sub>1</sub>	Slip-on B <sub>2</sub>	Lap Joint B <sub>3</sub>	Welding Neck Y <sub>1</sub>	Slip-on Socket Y <sub>2</sub>	Lap Joint Y <sub>3</sub>
4	10.00	1.38	6.19	0.44	To be specified by purchaser.	4.57	4.60	SIZES 1/2" THRU 3 1/2"		
5	11.00	1.50	7.31	0.44		5.66	5.69	3.50	2.00	2.00
6	12.50	1.62	8.50	0.50		6.72	6.75	4.00	2.12	2.12
8	15.00	1.88	10.62	0.50		8.72	8.75	4.06	2.25	2.25
10	17.50	2.12	12.75	0.50		10.88	10.92	4.62	2.69	2.69
12	20.50	2.25	15.00	0.50		12.88	12.92	4.88	2.88	4.00
14	23.00	2.38	16.25	0.50		14.14	14.18	5.38	3.12	4.25
16	25.50	2.50	18.50	0.50		16.16	16.19	5.88	3.31	4.62
18	28.00	2.62	21.00	0.50		18.18	18.20	6.00	3.69	5.00
20	30.50	2.75	23.00	0.50		20.20	20.25	6.50	3.88	5.38
24	36.00	3.00	27.25	0.50	24.25	24.25	6.62	4.00	5.75	
								6.88	4.50	6.62

Thickness and length through hub do not include 1/4" raised face.

ASME B16.5

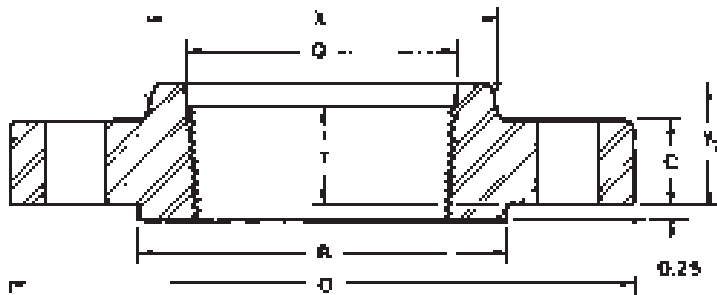

**THREADED**

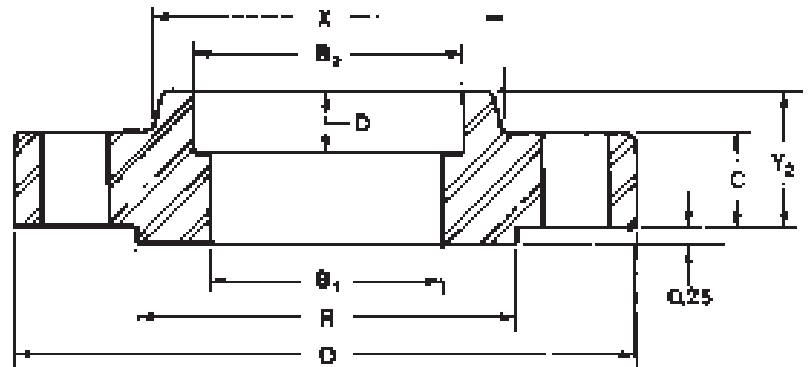

**SOCKET WELD**  
(1/2" TO 3" ONLY)

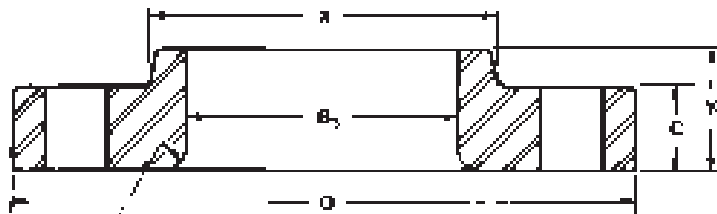

**LAP JOINT**

Min. Thread Length T	Dia. Hub at Bevel A	Hub Dia. X	Drilling			Approx. Weight				Nominal Size
			Bolt Circle	Dia. Holes	No. Holes	Welding Neck	Slip-on Thrd. Sock. W.	Lap Joint	Blind	
ARE IDENTICAL WITH CLASS 600										
1.44	4.50	5.75	7.88	1.00	8	35	26	25	33	4
1.69	5.56	7.00	9.25	1.00	8	43	31	29	44	5
1.81	6.63	8.12	10.62	1.00	12	57	44	42	61	6
2.00	8.63	10.25	13.00	1.12	12	89	67	64	100	8
2.19	10.75	12.62	15.25	1.25	16	125	91	110	155	10
2.38	12.75	14.75	17.75	1.38	16	175	130	150	225	12
2.50	14.00	16.75	20.25	1.38	20	230	180	205	290	14
2.69	16.00	19.00	22.50	1.50	20	295	235	260	370	16
2.75	18.00	21.00	24.75	1.50	24	350	285	315	455	18
2.88	20.00	23.12	27.00	1.62	24	425	345	385	587	20
3.25	24.00	27.62	32.00	1.88	24	620	510	570	890	24

See 300 Class dimensions for dimensions "Q" and "D".

ASME B16.5

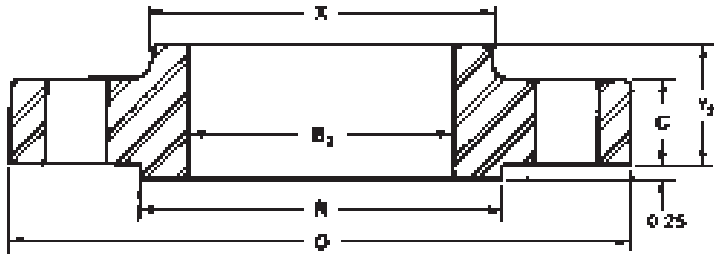

**SLIP-ON**

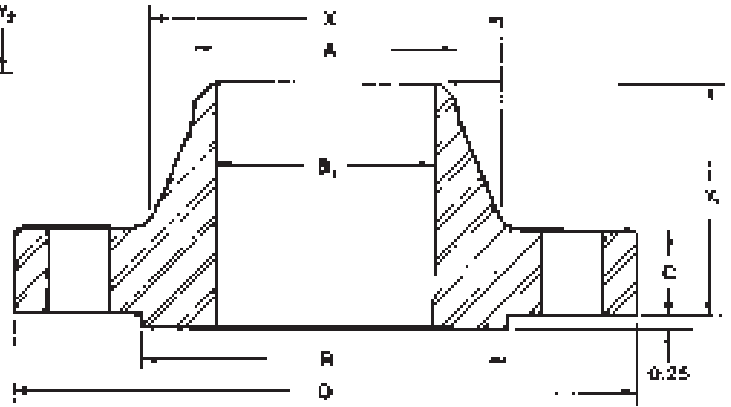

**WELDING NECK**

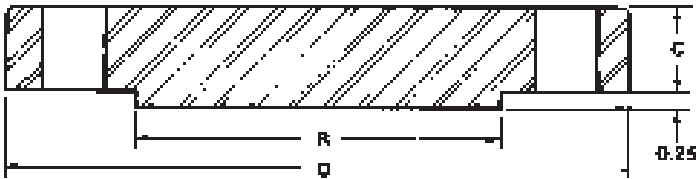

**BLIND**

Nominal Size	Common Dimensions				Bore			Length Thru Hub		
	Outside Dia. O	Thk. C	Raised Face Dia. R	Fillet Radius r	Welding Neck Socket B <sub>1</sub>	Slip-on B <sub>2</sub>	Lap Joint B <sub>3</sub>	Welding Neck Y <sub>1</sub>	Slip-on Socket Y <sub>2</sub>	Lap Joint Y <sub>3</sub>
1/2	3.75	0.56	1.38	0.12	To be specified by purchaser.	0.88	0.90	2.06	0.88	0.88
3/4	4.62	0.62	1.69	0.12		1.09	1.11	2.25	1.00	1.00
1	4.88	0.69	2.00	0.12		1.36	1.38	2.44	1.06	1.06
1 1/4	5.25	0.81	2.50	0.19		1.70	1.72	2.62	1.12	1.12
1 1/2	6.12	0.88	2.88	0.25		1.95	1.97	2.75	1.25	1.25
2	6.50	1.00	3.62	0.31		2.44	2.46	2.88	1.44	1.44
2 1/2	7.50	1.12	4.12	0.31		2.94	2.97	3.12	1.62	1.62
3	8.25	1.25	5.00	0.38		3.57	3.60	3.25	1.81	1.81
3 1/2	9.00	1.38	5.50	0.38		4.07	4.10	3.38	1.94	1.94
4	10.75	1.50	6.19	0.44		4.57	4.60	4.00	2.12	2.12
5	13.00	1.75	7.31	0.44		5.66	5.69	4.50	2.38	2.38
6	14.00	1.88	8.50	0.50		6.72	6.75	4.62	2.62	2.62
8	16.50	2.19	10.62	0.50		8.72	8.75	5.25	3.00	3.00
10	20.00	2.50	12.75	0.50		10.88	10.92	6.00	3.38	4.38
12	22.00	2.62	15.00	0.50	12.88	12.92	6.12	3.62	4.62	
14	23.75	2.75	16.25	0.50	14.14	14.18	6.50	3.69	5.00	
16	27.00	3.00	18.50	0.50	16.16	16.19	7.00	4.19	5.50	
18	29.25	3.25	21.00	0.50	18.18	18.20	7.25	4.62	6.00	
20	32.00	3.50	23.00	0.50	20.20	20.25	7.50	5.00	6.50	
24	37.00	4.00	27.25	0.50	24.25	24.25	8.00	5.50	7.25	

Thickness and length through hub do not include 1/4" raised face.



ASME B16.5

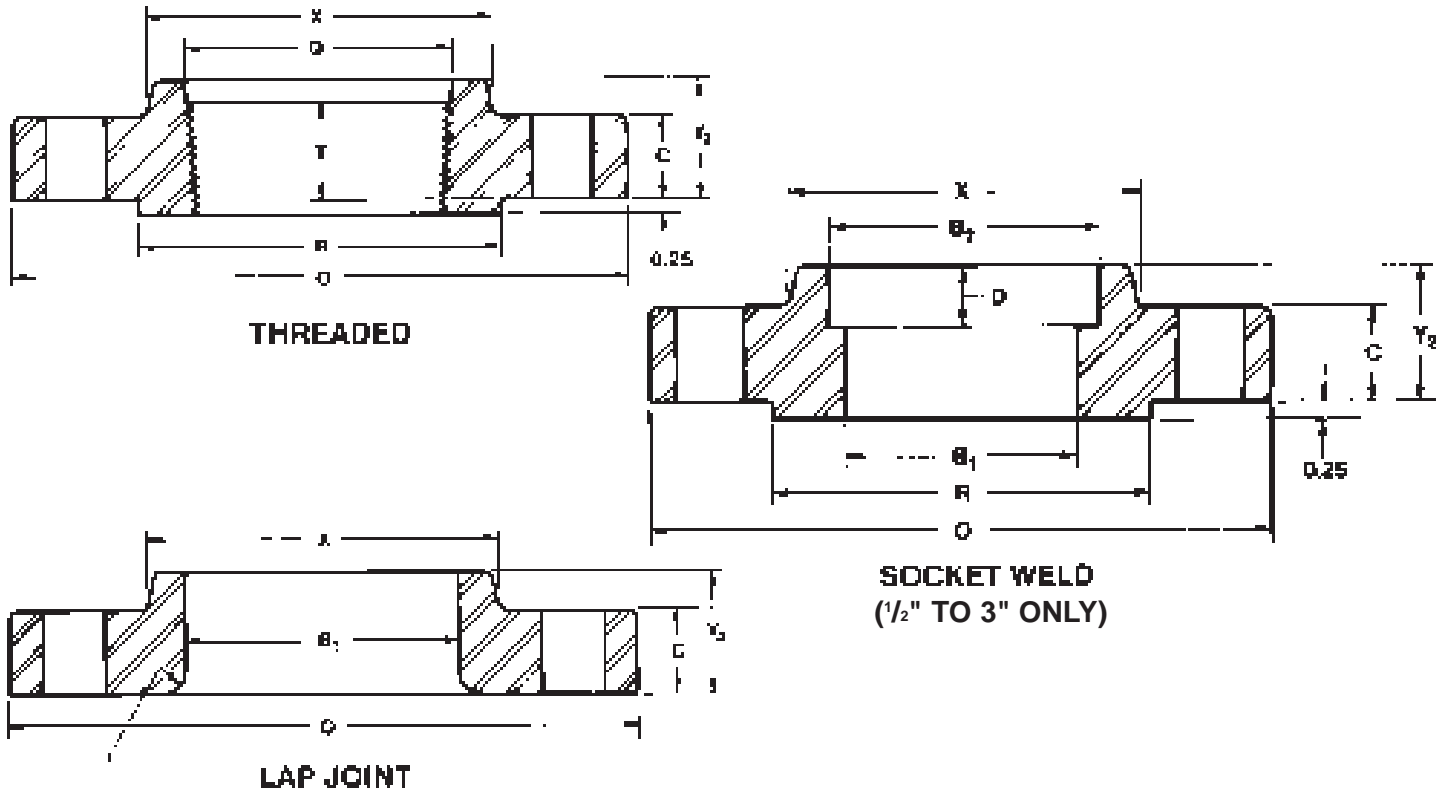

Min. Thread Length T	Depth of Socket D	Dia. Hub at Bevel A	Hub Dia. X	Drilling			Approx. Weight				Nominal Size
				Bolt Circle	Dia. Holes	No. Holes	Welding Neck	Slip-on Thrd. Sock. W.	Lap Joint	Blind	
0.62	0.38	0.84	1.50	2.62	0.62	4	2	2	2	2	1/2
0.62	0.44	1.05	1.88	3.25	0.75	4	4	3	3	3	3/4
0.69	0.50	1.32	2.12	3.50	0.75	4	4	4	4	4	1
0.81	0.56	1.66	2.50	3.88	0.75	4	6	5	5	5	1 1/4
0.88	0.62	1.90	2.75	4.50	0.88	4	8	7	7	8	1 1/2
1.12	0.69	2.38	3.31	5.00	0.75	8	12	9	9	10	2
1.25	0.75	2.88	3.94	5.88	0.88	8	18	13	12	15	2 1/2
1.38	0.81	3.50	4.62	6.62	0.88	8	23	16	15	20	3
1.56	0.88	4.00	5.25	7.25	1.00	8	26	21	20	29	3 1/2
1.62	0.94	4.50	6.00	8.50	1.00	8	42	37	36	41	4
1.88	0.94	5.56	7.44	10.50	1.12	8	68	63	61	68	5
2.00	1.06	6.62	8.75	11.50	1.12	12	81	80	78	86	6
2.25	1.25	8.62	10.75	13.75	1.25	12	120	115	110	140	8
2.56	1.31	10.75	13.50	17.00	1.38	16	190	170	170	230	10
2.75	1.56	12.75	15.75	19.25	1.38	20	225	200	200	295	12
2.88	1.62	14.00	17.00	20.75	1.50	20	280	230	250	355	14
3.06	1.75	16.00	19.50	23.75	1.62	20	390	330	365	495	16
3.12	1.94	18.00	21.50	25.75	1.75	20	475	400	435	630	18
3.25	2.12	20.00	24.00	28.50	1.75	24	590	510	570	810	20
3.62	2.50	24.00	28.25	33.00	2.00	24	830	730	810	1250	24

See 300 Class dimensions for dimensions "Q" and "D".

# Class 900

## ASME B16.5

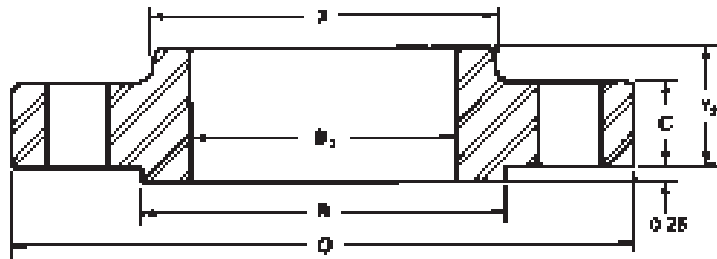

**SLIP-ON**

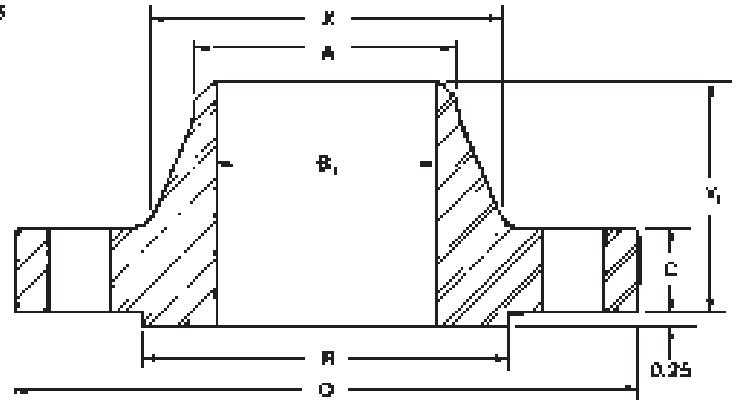

**WELDING NECK**

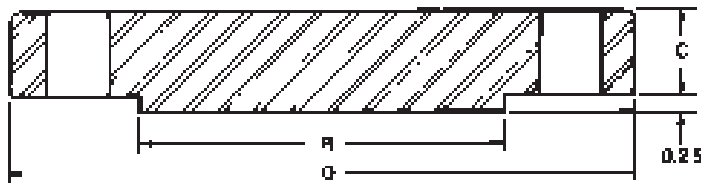

**BLIND**

Nominal Size	Common Dimensions				Bore			Length Thru Hub		
	Outside Dia. O	Thk. C	Raised Face Dia. R	Fillet Radius r	Welding Neck Socket B <sub>1</sub>	Slip-on B <sub>2</sub>	Lap Joint B <sub>3</sub>	Welding Neck Y <sub>1</sub>	Slip-on Socket Y <sub>2</sub>	Lap Joint Y <sub>3</sub>
3	9.50	1.50	5.00	0.38	To be specified by purchaser.	3.57	3.60	SIZES 1/2" THRU 2 1/2"		
4	11.50	1.75	6.19	0.44		4.57	4.60	4.00	2.12	2.12
5	13.75	2.00	7.31	0.44		5.66	5.69	4.50	2.75	2.75
6	15.00	2.19	8.50	0.50		6.72	6.75	5.00	3.13	3.13
8	18.50	2.50	10.62	0.50		8.72	8.75	5.50	3.38	3.38
10	21.50	2.75	12.75	0.50		10.88	10.92	6.38	4.00	4.50
12	24.00	3.12	15.00	0.50		12.88	12.92	7.25	4.25	5.00
14	25.25	3.38	16.25	0.50		14.14	14.18	7.88	4.62	5.62
16	27.75	3.50	18.50	0.50		16.16	16.19	8.38	5.12	6.12
18	31.00	4.00	21.00	0.50		18.18	18.20	8.50	5.25	6.50
20	33.75	4.25	23.00	0.50		20.20	20.25	9.00	6.00	7.50
24	41.00	5.50	27.25	0.50		24.25	24.25	9.75	6.25	8.25
								11.50	8.00	10.50

Thickness and length through hub do not include 1/4" raised face.

ASME B16.5

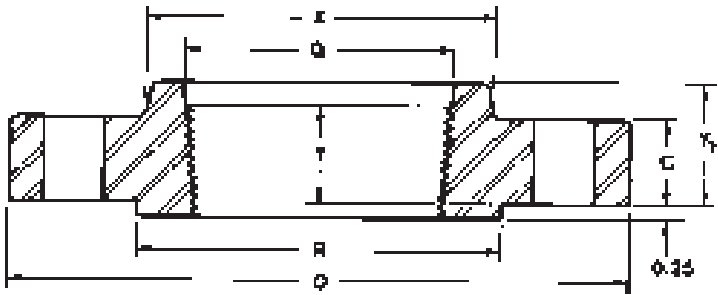

**THREADED**

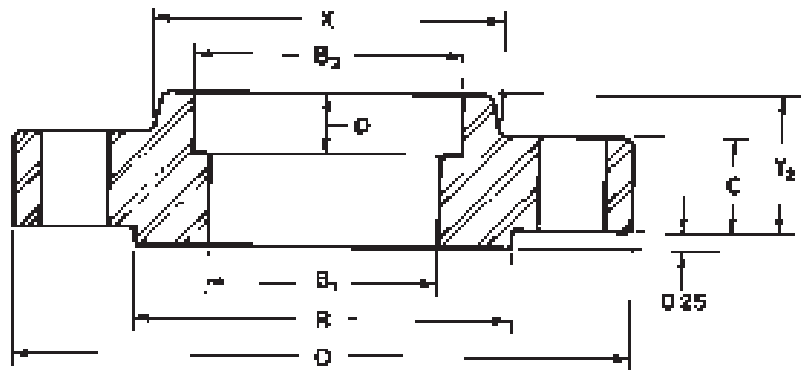

**SOCKET WELD  
(1/2" TO 3" ONLY)**

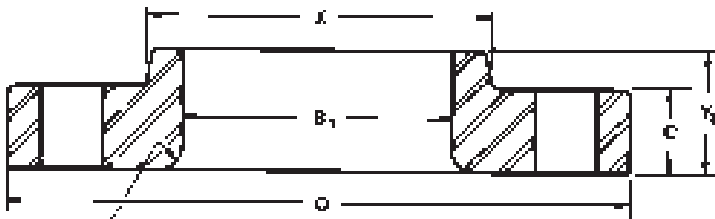

**LAP JOINT**

Min. Thread Length T	Dia. Hub at Bevel A	Hub Dia. X	Drilling			Approx. Weight				Nominal Size
			Bolt Circle	Dia. Holes	No. Holes	Welding Neck	Slip-on Thrd. Sock. W.	Lap Joint	Blind	
ARE IDENTICAL WITH CLASS 600										
1.62	3.50	5.00	7.50	1.00	8	31	26	25	29	3
1.88	4.50	6.25	9.25	1.25	8	53	53	51	54	4
2.12	5.56	7.50	11.00	1.38	8	86	83	81	87	5
2.25	6.63	9.25	12.50	1.25	12	110	110	105	115	6
2.50	8.63	11.75	15.50	1.50	12	175	170	190	200	8
2.81	10.75	14.50	18.50	1.50	16	260	245	275	290	10
3.00	12.75	16.50	21.00	1.50	20	325	325	370	415	12
3.25	14.00	17.75	22.00	1.62	20	400	400	415	520	14
3.38	16.00	20.00	24.25	1.75	20	495	425	465	600	16
3.50	18.00	22.25	27.00	2.00	20	680	600	650	850	18
3.62	20.00	24.50	29.50	2.12	20	830	730	810	1075	20
4.00	24.00	29.50	35.50	2.62	20	1500	1400	1550	2025	24

See 300 Class dimensions for dimensions "Q" and "D".

ASME B16.5

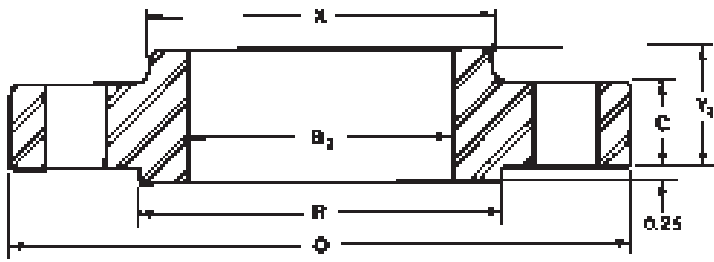

**SLIP-ON**

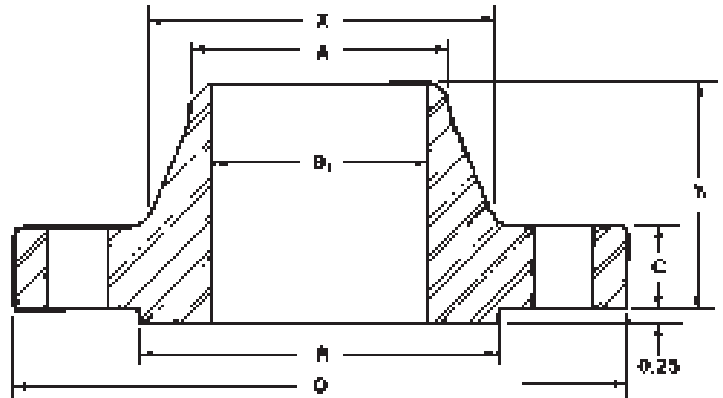

**WELDING NECK**

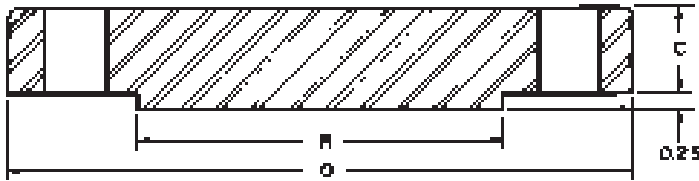

**BLIND**

Nominal Size	Common Dimensions				Bore			Length Thru Hub		
	Outside Dia. O	Thk. C	Raised Face Dia. R	Fillet Radius r	Welding Neck Socket B <sub>1</sub>	Slip-on B <sub>2</sub>	Lap Joint B <sub>3</sub>	Welding Neck Y <sub>1</sub>	Slip-on Socket Y <sub>2</sub>	Lap Joint Y <sub>3</sub>
1/2	4.75	0.88	1.38	0.12	To be specified by purchaser.	0.88	0.90	2.38	1.25	1.25
3/4	5.12	1.00	1.69	0.12		1.09	1.11	2.75	1.38	1.38
1	5.88	1.12	2.00	0.12		1.36	1.38	2.88	1.62	1.62
1 1/4	6.25	1.12	2.50	0.19		1.70	1.72	2.88	1.62	1.62
1 1/2	7.00	1.25	2.88	0.25		1.95	1.97	3.25	1.75	1.75
2	8.50	1.50	3.62	0.31		2.44	2.46	4.00	2.25	2.25
2 1/2	9.62	1.63	4.12	0.31		2.94	2.97	4.12	2.50	2.50
3	10.50	1.88	5.00	0.38		3.57	3.60	4.62	2.88	2.88
4	12.25	2.12	6.19	0.44		4.57	4.60	4.88	3.56	3.56
5	14.75	2.88	7.31	0.44		5.66	5.69	6.12	4.12	4.12
6	15.50	3.25	8.50	0.50		6.72	6.75	6.75	4.69	4.69
8	19.00	3.62	10.62	0.50		8.72	8.75	8.38	5.62	5.62
10	23.00	4.25	12.75	0.50		10.88	10.92	10.00	6.25	7.00
12	26.50	4.88	15.00	0.50		12.88	12.92	11.12	7.12	8.62
14	29.50	5.25	16.25	0.50	14.14	14.18	11.75	—	9.50	
16	32.50	5.75	18.50	0.50	16.16	16.19	12.25	—	10.25	
18	36.00	6.38	21.00	0.50	18.18	18.20	12.88	—	10.88	
20	38.75	7.00	23.00	0.50	20.20	20.25	14.00	—	11.50	
24	46.00	8.00	27.25	0.50	24.25	24.25	16.00	—	13.00	

Thickness and length through hub do not include 1/4" raised face.

ASME B16.5

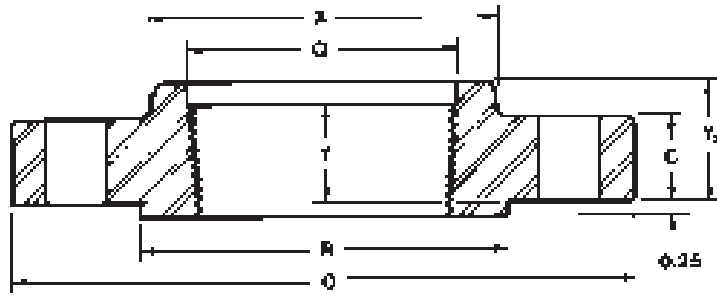

**THREADED**  
(1/2" TO 2 1/2" ONLY)

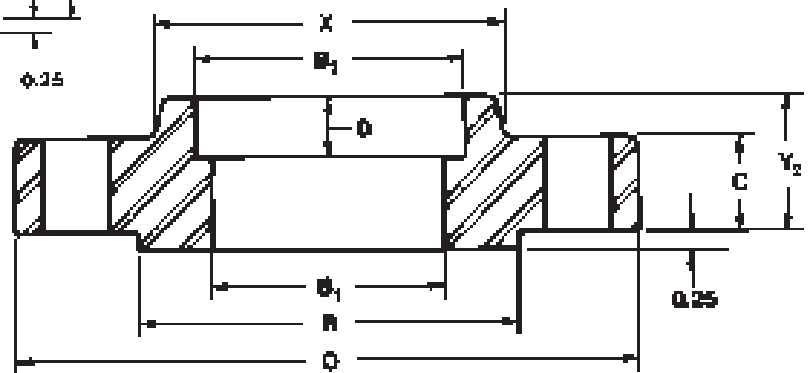

**SOCKET WELD**  
(1/2" TO 2 1/2" ONLY)

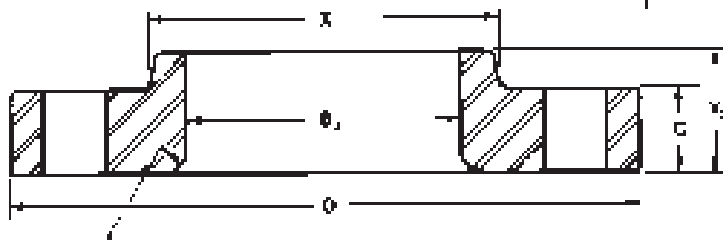

**LAP JOINT**

Min. Thread Length T	Depth of Socket D	Dia. Hub at Bevel A	Hub Dia. X	Drilling			Approx. Weight				Nominal Size
				Bolt Circle	Dia. Holes	No. Holes	Welding Neck	Slip-on Thrd. Sock. W.	Lap Joint	Blind	
0.88	0.38	0.84	1.50	3.25	0.88	4	5	4	4	4	1/2
1.00	0.44	1.05	1.75	3.50	0.88	4	6	5	5	6	3/4
1.12	0.50	1.32	2.06	4.00	1.00	4	9	8	8	8	1
1.19	0.56	1.66	2.50	4.38	1.00	4	10	9	9	9	1 1/4
1.25	0.62	1.90	2.75	4.88	1.12	4	13	12	12	13	1 1/2
1.50	0.69	2.38	4.12	6.50	1.00	8	25	25	25	25	2
1.88	0.75	2.88	4.88	7.50	1.12	8	36	36	35	35	2 1/2
2.00	0.81	3.50	5.25	8.00	1.25	8	48	48	47	48	3
2.25	0.94	4.50	6.38	9.50	1.38	8	73	73	75	73	4
2.50	0.94	5.56	7.75	11.50	1.62	8	130	130	140	140	5
2.75	1.06	6.63	9.00	12.50	1.50	12	165	165	170	160	6
3.00	1.25	8.63	11.50	15.50	1.75	12	275	260	285	300	8
3.31	1.31	10.75	14.50	19.00	2.00	12	455	435	485	510	10
3.63	1.56	12.75	17.75	22.50	2.12	16	690	580	630	690	12
—	1.63	14.00	19.50	25.00	2.38	16	940	—	890	975	14
—	1.75	16.00	21.75	27.75	2.62	16	1250	—	1150	1300	16
—	1.94	18.00	23.50	30.50	2.88	16	1625	—	1475	1750	18
—	2.13	20.00	25.25	32.75	3.12	16	2050	—	1775	2225	20
—	2.50	24.00	30.00	39.00	3.62	16	3325	—	2825	3625	24

See 300 Class dimensions for dimensions "Q" and "D".

ASME B16.5

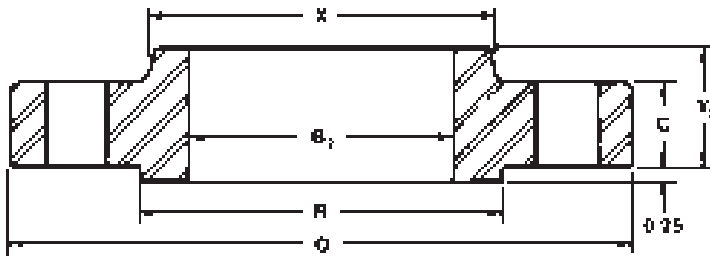

**SLIP-ON**

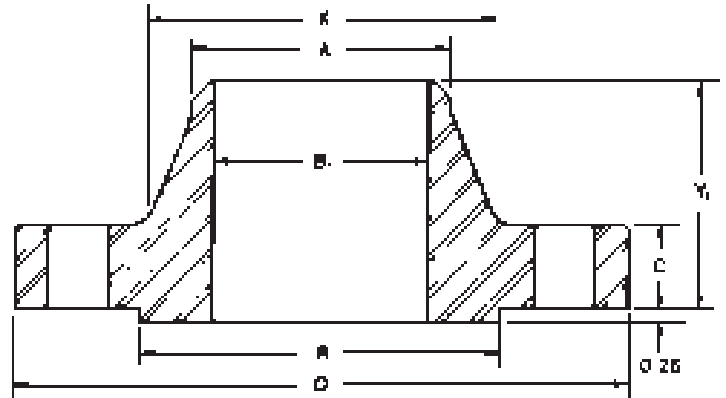

**WELDING NECK**

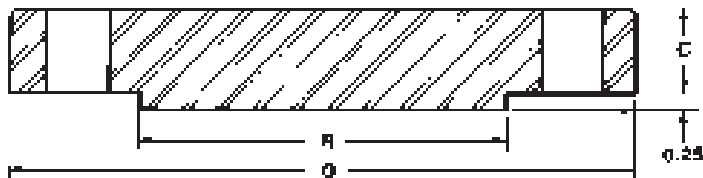

**BLIND**

Nominal Size	Common Dimensions				Bore			Length Thru Hub		
	Outside Dia. O	Thk. C	Raised Face Dia. R	Fillet Radius r	Welding Neck Socket B <sub>1</sub>	Slip-on B <sub>2</sub>	Lap Joint B <sub>3</sub>	Welding Neck Y <sub>1</sub>	Slip-on Socket Y <sub>2</sub>	Lap Joint Y <sub>3</sub>
1/2	5.25	1.19	1.38	0.12	To be specified by purchaser.	0.88	0.90	2.88	1.56	1.56
3/4	5.50	1.25	1.69	0.12		1.09	1.11	3.12	1.69	1.69
1	6.25	1.38	2.00	0.12		1.36	1.38	3.50	1.88	1.88
1 1/4	7.25	1.50	2.50	0.19		1.70	1.72	3.75	2.06	2.06
1 1/2	8.00	1.75	2.88	0.25		1.95	1.97	4.38	2.38	2.38
2	9.25	2.00	3.62	0.31		2.44	2.46	5.00	2.75	2.75
2 1/2	10.50	2.25	4.12	0.31		2.94	2.97	5.62	3.12	3.12
3	12.00	2.62	5.00	0.38		3.57	3.60	6.62	3.62	3.62
4	14.00	3.00	6.19	0.44		4.57	4.60	7.50	4.25	4.25
5	16.50	3.62	7.31	0.44		5.66	5.69	9.00	5.12	5.12
6	19.00	4.25	8.50	0.50		6.72	6.75	10.75	6.00	6.00
8	21.75	5.00	10.62	0.50		8.72	8.75	12.50	7.00	7.00
10	26.50	6.50	12.75	0.50	10.88	10.92	16.50	9.00	9.00	
12	30.00	7.25	15.00	0.50	12.88	12.92	18.25	10.00	10.00	

Class 2500 Slip-Ons are not included in ASME B16.5 specifications.  
Thickness and length through hub do not include 1/8" raised face.

ASME B16.5

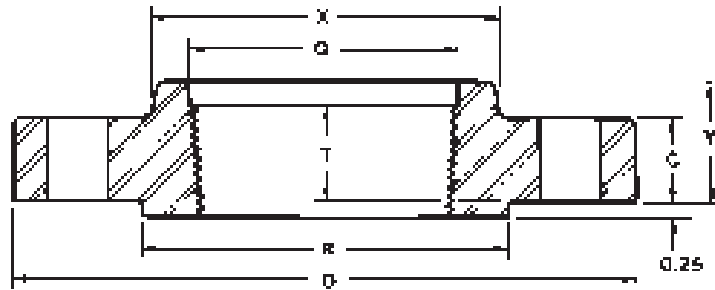

**THREADED**

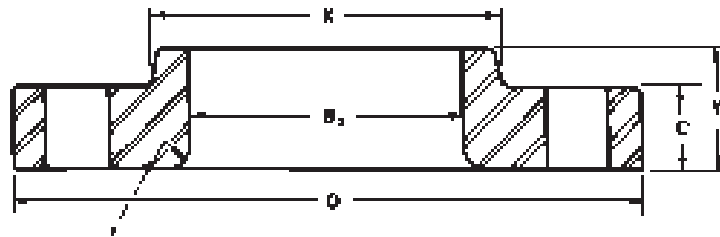

**LAP JOINT**

Min. Thread Length T	Dia. Hub at Bevel A	Hub Dia. X	Drilling			Approx. Weight				Nominal Size
			Bolt Circle	Dia. Holes	No. Holes	Welding Neck	Slip-on Thrd. Sock. W.	Lap Joint	Blind	
1.12	0.84	1.69	3.50	0.88	4	7	7	7	7	1/2
1.25	1.05	2.00	3.75	0.88	4	8	8	8	8	3/4
1.38	1.32	2.25	4.25	1.00	4	12	11	11	11	1
1.50	1.66	2.88	5.12	1.12	4	17	16	16	17	1 1/4
1.75	1.90	3.12	5.75	1.25	4	25	22	22	23	1 1/2
2.00	2.38	3.75	6.75	1.12	8	42	38	37	39	2
2.25	2.88	4.50	7.75	1.25	8	52	55	53	56	2 1/2
2.50	3.50	5.25	9.00	1.38	8	94	83	80	86	3
2.75	4.50	6.50	10.75	1.62	8	145	125	120	135	4
3.00	5.56	8.00	12.75	1.88	8	245	210	205	225	5
3.25	6.63	9.25	14.50	2.12	8	380	325	315	345	6
3.75	8.63	12.00	17.25	2.12	12	580	485	470	530	8
4.25	10.75	14.75	21.25	2.62	12	1075	930	900	1025	10
4.75	12.75	17.38	24.38	2.88	12	1525	1100	1100	1300	12

See 300 Class dimensions for dimensions "Q" and "D".